

# TRAILERFEST TIMES

September 27-30, 2018

A Vintage Camper Trailers Publication

Volume 1 Issue 1

## TRAILERITES INVAD PLYMOUTH CALIFORNIA

### WELCOME!

Trailerfest has taken on many great themes over the years. Many of the trailerites that have attended multiple Trailerfest events share with us their favorites. Themes like “Christmas in the Trailer Park”, “Trailerfiesta” (Cinco De Mayo), and “Back to School” are just a few that seem to be some of the more memorable. The Trailerfest theme is usually inspired by suggestions from the attendees. We take suggestions as inspiration to help us decide the next theme for a Trailerfest rally. The theme must have broad appeal, connect to the past and be family friendly.

### Military Appreciation

Martha Kaufeldt gave us the inspiration for the “Back to the 60’s, Hippiefest” (Spring 2018). The political climate of that era was very different than that of just a couple of decades before. In putting together the spring rally, we came up with the idea of doing a “Military Appreciation” theme. We always try to integrate patriotism in our events. We fly an American flag at our trailer to pay respect to the country that provides us with the opportunity to prosper and enjoy hobbies like vintage camping. This theme has come to life with things like a Glenn Miller inspired big band, dog tags and this newspaper. When we reached out to the attendees

and Trailer Parks accommodated those on the move to improve their quality of living. New highways created better access to once far away destinations. The Highway Act of 1956 provided \$26 thousand-million, the largest public works expenditure in U.S. history, linking together all parts of the country. In the postwar period the West and the Southwest continued to grow -- a trend that would continue through the end of the century. Sun Belt cities like Houston, Texas; Miami, Florida; Albuquerque, New Mexico; and Tucson and Phoenix, Arizona, expanded rapidly. Los Angeles, California, moved ahead of Philadelphia, Pennsylvania, as the third largest U.S. city. By 1963 California had more people than New York.



### THANK YOU FOR YOUR SERVICE!



Paul Carwin is helo-lifted from the submarine, USS Snook so he could deliver classified information. *Western Pacific, 1962.*

of this fall’s event for their military service we had no idea how many had served. We were pleasantly surprised with over 50 responses! This circle of friends represents every branch, decade and ranks from serviceman to officers.

### Post War Prosperity

The decade and a half after World War II, the United States experienced phenomenal economic growth. The war brought the return of prosperity, and in the postwar period the United States solidified its position as the world’s richest country. More Americans now considered themselves part of the “middle class.” The automobile and travel trailer industries were partially responsible for this boom. The number of automobiles produced annually quadrupled between 1946 and 1955. A housing boom, stimulated in part by affordable mortgages for servicemen returning from duty, helped fuel the expansion. In the years immediately following WWII, approximately 8% of Americans lived in mobile housing. Americans were on the move. Auto and Trailer Courts, Motor Lodges, hotels

### Trailerfest Past and Future

We started hosting rallies almost by accident. In 2011 we wanted to get a group of friends together and go camping. I called around and found out that the KOA campground at Tower Park in Lodi, California was having an event they called “Towerfest”. It was a tiki themed event complete with hula dancers, food and all of the amenities that the park had to offer. That year there were less than two dozen of us and we had a blast. The next year when we put the word out, over 50 trailers registered. Over a span of six years, we worked with different park managers and even new owners when Yogi Bear Jellystone Resorts purchased the park from KOA in 2016. The name “Trailer-

fest” was adopted from the park’s event called “Towerfest” after the park quit hosting that event. By our fourth year we were selling out the entire park with over 250 trailers and all of the cabins filling up months in advance with waiting lists of people that wanted to come. In 2016 the new owners of the park let us know that their future plans included more cabins and less campsites. Already busting at the seams, we had to find a different park with at least as many campsites. After much searching we ended up at the 49’er in Plymouth, CA.

Trailerfest 2019 will now host three different events in three different locations. Glamperfest in Red Bluff, CA in May, Rockabilly Rally in Hollister, CA in June and back to Plymouth in the fall. The fall theme will be “White Wedding, an 80’s Love Story”. Be prepared to renew your vows and crash the reception!

[www.TrailerfestRally.com](http://www.TrailerfestRally.com)



★ ★ ★ ★ ★  
**BOOT CAMP**  
ELITE TRAINING

March 7-10, 2019 ★ Hollister, CA  
[www.VCTBootCamp.com](http://www.VCTBootCamp.com)

## A RESTORATION LEARNING EXPERIENCE

# STEVE MENDENHALL

8/3/1940 - 5/25/2018

This past spring we said goodbye to our camping buddy Steve Mendenhall. Steve and Terry Mendenhall have been part of Trailerfest rallies from the very beginning. Steve was kind and welcoming to everyone he met. You might remember him as the man with the toy trailer collection. We are thankful that Terry and daughter, Amy, are still camping with us and we can remember Steve and his kindness.



Steve joined the Air Force after one year of college in June of 1959. His dreams were to become a jet engine mechanic and to see the world. Well the first one came true. He went to Texas for basic and special training. Of his 17 classmates, 16 went overseas while Steve was stationed at Beale Air Force Base in Marysville, CA (his home town). At that time, in 1960, the base was being changed from Camp Beale, an old Army base to the new Beale Air force base. Housing was limited and when they found out his parents lived just 25 miles away he was put on separate rations and sent home. He was a jet engine mechanic on the B-52 bombers and KC-135 refueling jets, for the 456 Field Maintenance Squadron (SAC) during the Cuban missile crisis. At that time they had two B-52 bombers in the air 24 hours a day and four planes on the runway ready to go at any time.



Steve & Terry at the Woodson Bridge Rally 2018



Ready for duty, even if it wasn't far from home.



Steve & Terry's collection of toy trailers, their Boles Aero and their 1955 Chevy convertible were featured in the first VCT book.



# BATTLE PLANS

Thursday 6 pm: Potluck Dinner

Friday 8 am to 9 am: Biscuits and Gravy or Oatmeal Breakfast. (Coffee ready by 7:30 am)

Friday 6 pm: Kellie's Canteen! Bring your favorite beverage (and some to share) and/or a finger food. A social affair, 1940's style.

Saturday 7:30 am: Coffee and Donuts  
Pajama Military March 8:30 am: Come with your own cadence and lead the troops. Wear your PJ's or a uniform. March or ride your bike.

Saturday Open House, 10 am to 2 pm  
Classic cars and Military Vehicles are invited!

Saturday Night 6:00 pm to 9:00 pm:  
Root Beer Floats and Live Music at the Pavilion  
A "Glenn Miller" 19 piece orchestra!  
Sponsored by Hagerty Insurance



**HAGERTY**  
FOR PEOPLE WHO LOVE CARS®

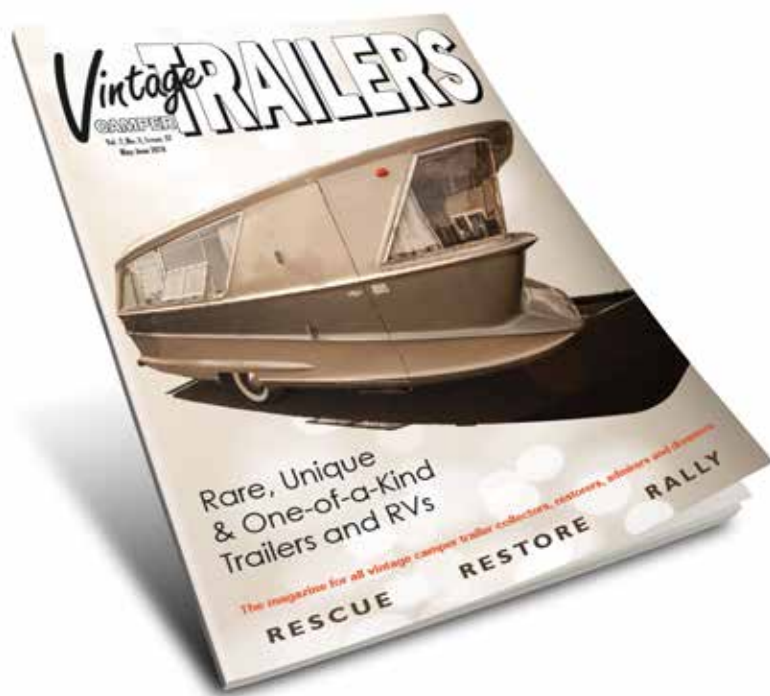

**MADE IN AMERICA  
BY AMERICANS  
SUPPORT AMERICA  
GIVE A GIFT SUBSCRIPTION**

NAME \_\_\_\_\_

ADDRESS \_\_\_\_\_

CITY \_\_\_\_\_ STATE \_\_\_\_\_ ZIP \_\_\_\_\_

EMAIL \_\_\_\_\_ PHONE \_\_\_\_\_

Send \$32 to: VCT, PO Box 354, Elverta, CA 95626. (916) 572-8554

[www.VintageCamperTrailers.com](http://www.VintageCamperTrailers.com)

# OUR AMERICAN HEROES



**Charles Diffey**  
 US ARMY  
 SP4 Spearhead  
 12th Cavalry, 3rd Armored  
 1960-1963

TCQC Winner (Tank Crew Qualification Course) 1962 & 1963 at Grafenau Germany

- Good Conduct
- Distinguished Tank Crew 1963
- Sharpshooter M-1 & Rifle
- Marksman M-1
- Tank Weapons Expert
- Machine Gun Expert



Charles Diffey (above and below)



***“Word to the Nation: Guard zealously your right to serve in the Armed Forces, for without them, there will be no other rights to guard.”***

— President John F. Kennedy



**Barry Holland**  
 Army Staff Sergeant E-6,  
 1967 -1969  
 Bronze Star



**Bobby Rapp**  
 Ken and Karens Nephew  
 Army Sgt in the 82nd Airborne  
 Division. Afghanistan in 2008  
 died at age 22



**Eldon Lowe**  
 US Army, Corporal  
 1957



**Jay Bell**  
 Marine Corps Lance Corporal  
 1966 -1968  
 Meritorious Mast and served  
 in Vietnam



**Daniel Zen**  
 USMC Corporal  
 1977-1980  
 Honorable Discharge



**Dal Smilie**  
 Army Sgt E5  
 Vietnam



**Howdy Hoover**  
 Marine Corps Corporal  
 1965-1971



# OFFICERS CLUB

***“The supreme quality for leadership is unquestionably integrity. Without it, no real success is possible, no matter whether it is on a section gang, a football field, in an army, or in an office.”*** --General Dwight D. Eisenhower



**Mack Stewart, Jr.** (Yvonne’s Dad)  
Chief Warrant Officer 3 (CWO3)  
1950-1976

- Army Soldier’s Medal
- Bronze Star Medal with 3 Oak Leaf Clusters
- Joint Service Commendation Medal
- Army Commendation Medal with 2 Oak Leaf Clusters
- Army Good Conduct Medal 5 time recipient
- Army Occupation Medal
- National Defense Service Medal with One Oak Leaf Cluster
- Korean Service Medal with 4 stars
- Vietnam Service Medal 2 time recipient
- Korea Defense Service Medal
- Armed Forces Service Medal
- Republic of Vietnam Presidential Unit Citation Ribbon
- Korean Republic Presidential Unit Citation Ribbon
- United Nations Korea Service Medal
- Vietnam Campaign Medal
- United Nations Medal
- Republic of Korea War Service Medal



**Paul Carwin**  
USN Submarine service  
US Naval Academy graduate;  
Retired as Commander  
CO USSBN James Madison



**Robert Barnett**  
United States Air Force  
Captain  
1968-1973



**Phil Marler**  
USAF  
Lieutenant Colonel  
1970 -1991

- Department of Defense Superior Service Medal
- USAF Meritorious Service Medal with 3 Bronze Oak leaf Clusters
- USAF Commendation Medal
- USAF Longevity Service Award with 4 Oak Leaf Clusters
- National Defense Service Medal with 1 Bronze Star
- USAF Overseas Ribbon - Long
- USAF Training Ribbon
- USAF Outstanding Unit Award
- Small Arms Expert Marksmanship Ribbon - Pistol



Promotion to Major 1982 USAF SG - Phil and Ruthie Marler.

## GOD BLESS AMERICA

**MARTI'S Awnings** TRAILER

Custom Made Vintage Look Stripes Scallops

Fringe Sunbrella Fabrics Poles

MADE TO FIT ALL SHAPES AND SIZES

Marti Domyancic  
(530) 891-5120  
domy@sbcglobal.net

**MartisAwnings.com**



**Eric J. Frye**  
Army Colonel, MS  
1990-current

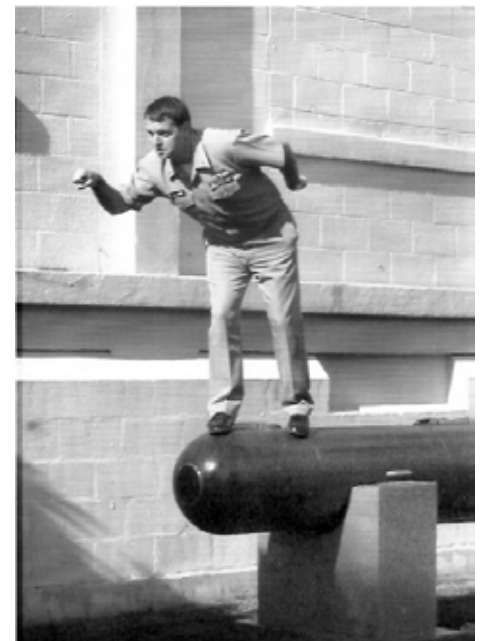

**Bob Gallagher**  
USN Command Master Chief (E-9)  
1980-2002

***“I only regret that I have but one life to lose for my country.”***  
-- Nathan Hale



# ALL GAVE SOME, SOME GAVE ALL

*"The object of war is not to die for your country but to make the other bastard die for his."* -- Gen. George S. Patton



**Micahel Smith**  
Army, SP4., M16  
1969-1972



**Lew Tift**  
US ARMY E-5  
1968-1970



**Sam Miller**  
US Marines E5 Sargent  
1964-1969



**Ronald Pickler**  
Army Rank E4  
1963 to 1966  
Sharp Shooter and Marksmen



**Mike Brockett**  
Army Nike missiles E-4  
1966-1968  
Honorable Discharge



**Michael O'Dell**  
USMC Sergeant 1980-1987  
Expert Rifleman  
Company Honorman  
Navy Unit Commendation  
Sea Service Deployment Ribbon  
Presidential Service Certificate  
Presidential Service Badge

*"Bravery is being the only one who knows you're afraid."* --Colonel David Hackworth



**Richard Mulligan**  
(Morning Waters Father)  
Air Force Lieutenant  
1954-1956



**Mike Williams**  
USAF Sargent  
1970 -1974



**Shawn Gomes**  
US Army SGT  
1992-1998  
Airborne

## NOT PICTURED

**Dan Donovan**  
Navy  
2nd Class Air Traffic Controller  
1966-1972

**Bob Slatter**  
US Navy

**Melvin Smith**  
Air Force  
Senior Master Sgt. E-8  
1967 -2000  
Vietnam

**Lionel "Lee" Terra**  
Army  
Corporal E4  
1960-1963

**Jarred William Hicketier**  
USMC  
Lance Corporal  
2010-2014  
Afghanistan Operation  
Enduring Freedom

**Larry Lobb**  
US Army  
Vietnam 1971

**Mike Conway**  
Marine Corp  
Corporal E-4  
1966-1972  
Air Combat Crewmant Metal  
Vietnam Vet

**Ed Hagen**  
Marine Corps  
Heavy Equipment Instructor

**Terry Michael Curran**  
(Kellie Cronin's Uncle)  
Army 1969,  
Vietnam Vet

**Greg Mahoney**  
(Kellie Cronin's dad)  
US Marine Cpl. 1966-1969  
Vietnam Vet

**Robert A.Schultz**  
US NAVY  
Aviation Machinist Mate  
2nd Class  
1954-1958

**Robert W. Detmar**  
US Navy  
Rate: ADJ 2  
1965-1968

**Steven Danner**  
Rank: E5 Engineman  
1967-1971

# BE ALL THAT YOU CAN BE - GO ARMY

# IN THE NAVY & COAST GUARD



**Patrick Bales**  
USN E4/ATN  
1960-1964  
Academic Award Winner



**John Nelson**  
USN, E-2  
1966-1970  
Served in Vietnam



**Rick Roe**  
US Navy 3rd Class Engineman  
1966 -1970. Vietnam National Defense Vietnam Campaign, Vietnam Service Medal, 2 Bronze Stars, Armed Forces Expedition Medal



**Con Oamek**  
US Navy PT2  
Petty Officer 2nd Class 1959-1963

***"What counts is not necessarily the size of the dog in the fight -- it's the size of the fight in the dog."*** -- Gen. Dwight D. Eisenhower



USAF A1C  
1966 -1968



U.S. Air Force Sergeant  
1971-1975



**Jack Karr**  
US Coast Guard  
Petty Officer 2nd, 1966-1970  
Good Conduct and Civil Defense

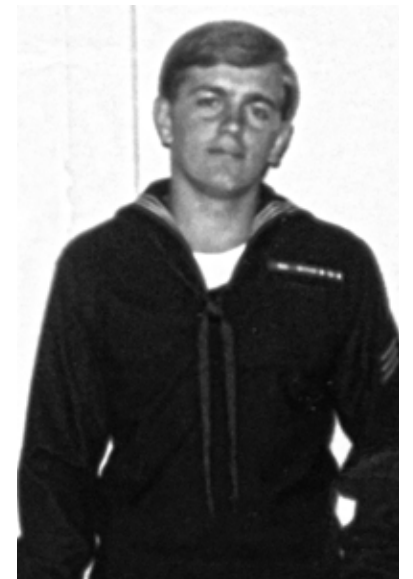

**Les Tussing,**  
Navy, DT-3, 1968-1971.  
Vietnam Armed Forces, Gallantry Cross USS Hancock , Vietnam Service Medal, National Defense Service Meda, INavy Unit Commendation USS Hancock .

# USAF



VCT

# GLAMPERFEST

VINTAGE TRAILER SHOW

RED BLUFF, CA *Made in America* MAY 2-5, 2019

WINE TASTING - LUAU - LIVE MUSIC  
OPEN AIR MARKET AND SWAP MEET

RESERVE TODAY



150 Sites

[www.glamperfest.com](http://www.glamperfest.com)

HOLLISTER, CA

# TRAILERFEST

FOOD, FUN & MUSIC

[www.trailerfesttrally.com](http://www.trailerfesttrally.com)

# ROCKABILLY RALLY

VINTAGE CAMPER TRAILERS

Live Music by the VINTAGE VANDALS

MEMPHIS BBQ

ROCK & ROLL POTLUCK

FASHION SHOW

OPEN HOUSE

JUNE 6-9, 2019

Traditional Hot Rod & Customs Carshow

# WOMEN IN SERVICE



**Denise Lucas**  
USN Hospital Corpsman  
2nd Class



**Michelle Baldwin**  
USAF Master Sergeant  
1978-2004  
Air Force Meritorious  
Service Medal, Air Force  
Commendation medals



**Sr. MSGT Nicole  
Domyancic Gill**  
17 yrs USAF  
Currently assigned to  
Elmendorf AFB  
Anchorage AK.

# CANDID CAMERA



**Michael Mahony**  
(Kellie Cronin's brother)  
US Marine  
Corporal  
Iraq and Afghanistan.  
2005-2009



**Bob Sullivan**  
US Army E-4  
1966-1968



**Rob Collins**  
United States Army  
Intelligence Unit - Specialist 4th Class  
1973-1976 - Stuttgart Germany



**John Hancock**  
Air Force Reserves. Staff Sergeant  
1976-1981



**Tim Jones**  
Army SP5  
Vietnam  
1969



**Michael Morris**  
Army SP5  
1967-1969  
ARCOM - Army  
Accommodation Medal



**Bob Gallagher**  
USN Command  
Master Chief  
(E-9)  
1980-2002

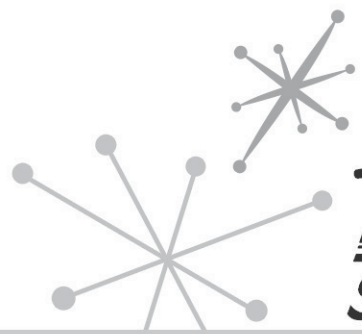

# Hemet Valley RV

## SIDING & STORAGE



**MADE IN THE  
USA**

**Phone: (951) 765-5075 • Toll Free: (800) 966-4878**

### Hemet Valley RV

has manufactured aluminum and fiberglass siding for the RV repair industry since 1995. We provide RV siding for repairs in California for Shasta, Lance, Coleman, Starcraft and Dutchmen, along with a variety of other brands, making it easy to refurbish and repair RV's.

Every member of our team makes a tremendous effort to make sure our customers get the products that they need, when they need them. We are committed to ensuring that our customers receive orders on time and on budget. Our friendly, dedicated staff is what makes our business successful.

**Owner/Operations Manager: Steve**  
Steve has been at the helm of Hemet Valley RV since he purchased the company in 2005. Specializing in RV refurbishment, Steve works closely with individual customers and industry partners.

**Office Manager, Sales and Customer Care: Tammy**  
Tammy keeps the "wheels turning" at Hemet Valley RV. She spends her time answering customers' questions and making sure that manufacturing, shipping, delivery times and payments are on time and in sync.

**Shop Foreman, Manufacturing Expert, Brains of the Operation: Rich**  
Richie is often referred to as the "captain of the shop." He spends his time making sure that every item is properly manufactured and installed to meet Hemet Valley's high quality standards.

**Assistant Shop Manager, Packaging and Materials: Rick**  
Rick is our designated go-to guy for special products and large orders. His skills and expertise in the shop ensure that orders are done on-time and that they exceed customer expectations.

**Office Secretary, Billing and Invoicing: Tisha**  
Tisha's time is spent assisting customers, managing orders, keeping records and much more. She is the primary organizational influence that keeps the front-office and back-office operations running smoothly.

If you have questions about any of the services available at Hemet Valley RV, give us a call at 951-765-5075 or email us at [hvrvmetal@verizon.net](mailto:hvrvmetal@verizon.net).

**IN BUSINESS SINCE  
2005**

# Guideline for Measuring RV Siding

**If metal is off coach:**  
measure from the top of the metal to the bottom of the S-lock (see drawing) and add 2-1/4".

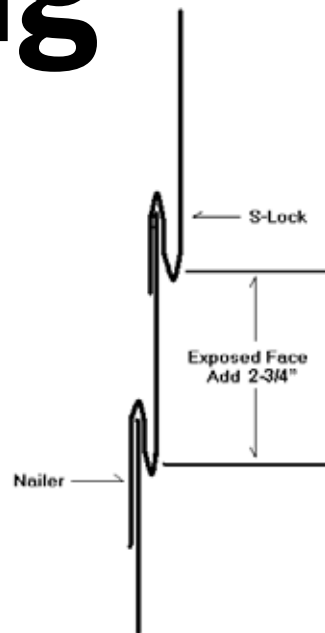
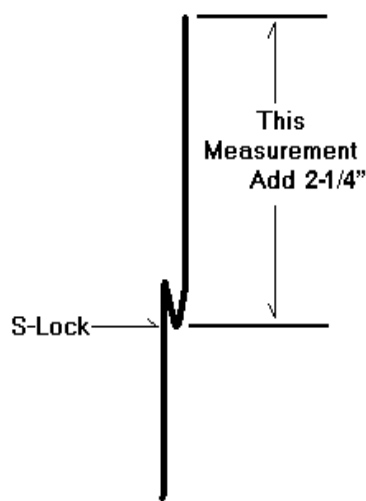

**If metal is on coach:**  
measure the exposed face (see drawing) add 2-3/4".

## PATTERNS

This is a sample of some of the many patterns that are offered. Almost any pattern can be achieved. Mesa patterns also come in 2", 3" and 4" patterns.

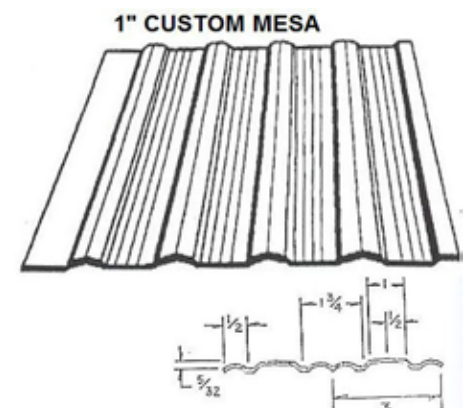
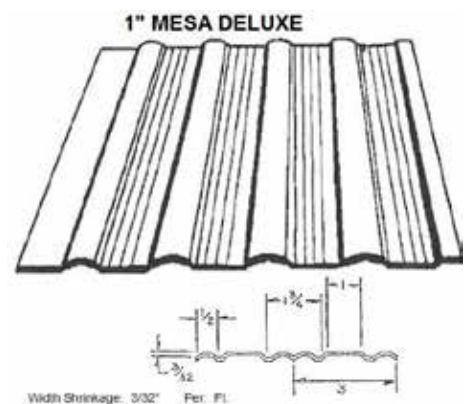
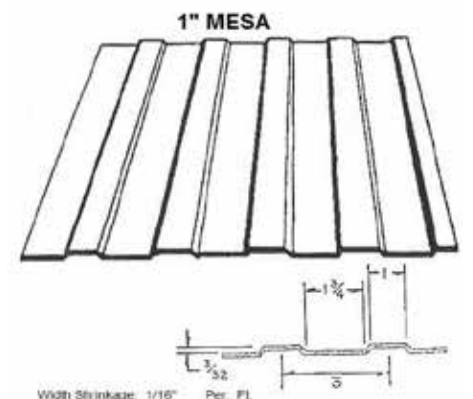

AVAILABLE IN 3" & 4" RUN

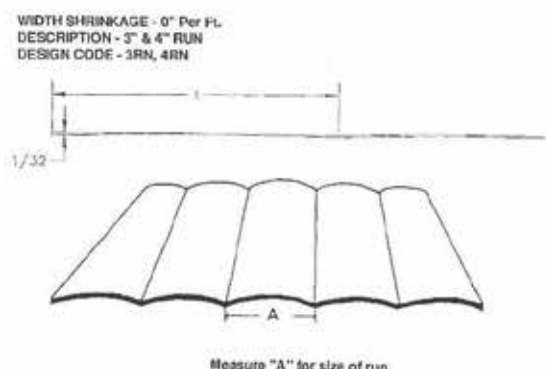

## COMMON TERMS

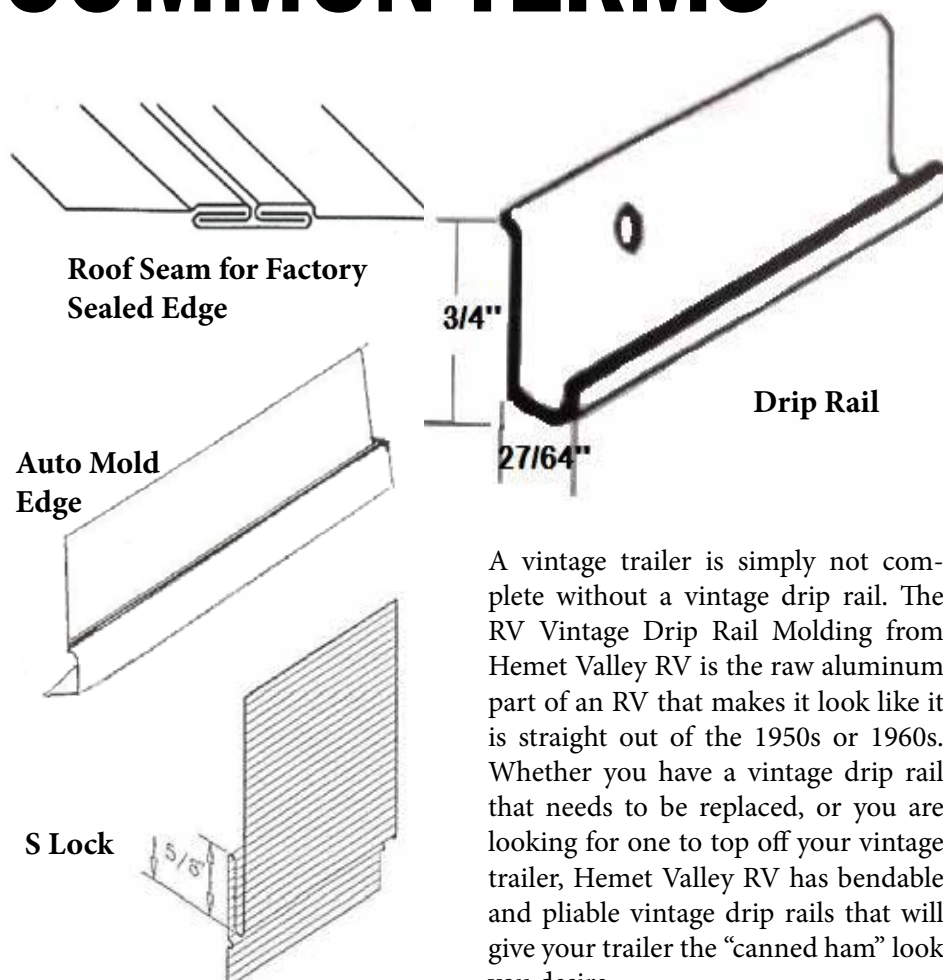

A vintage trailer is simply not complete without a vintage drip rail. The RV Vintage Drip Rail Molding from Hemet Valley RV is the raw aluminum part of an RV that makes it look like it is straight out of the 1950s or 1960s. Whether you have a vintage drip rail that needs to be replaced, or you are looking for one to top off your vintage trailer, Hemet Valley RV has bendable and pliable vintage drip rails that will give your trailer the "canned ham" look you desire.

[www.hemetvalleyrv.net](http://www.hemetvalleyrv.net)